



u-blox AG  
Zürcherstrasse 68  
8800 Thalwil  
Switzerland  
www.u-blox.com

Phone +41 1722 7444  
Fax +41 1722 7447  
info@u-blox.com

# LEA-4H GPS Receiver Module

Data Sheet

PRELIMINARY



## Abstract

Technical description of the high sensitivity ANTARIS 4 GPS Module with USB interface, SuperSense indoor GPS, integrated in the 17 x 22.4 mm housing, and for use with passive and active antennas.

*your position is our focus*

Data Sheet

<b>Title</b>	LEA-4H		
<b>Subtitle</b>	GPS Receiver Module		
<b>Doc Type</b>	Data Sheet	PRELIMINARY	
<b>Doc Id</b>	GPS.G4-MS4-05019-P2		
<b>Revision Index</b>	<b>Date</b>	<b>Name</b>	<b>Status / Comments</b>
P1	09. Sept 2005	GzB	Preliminary release
P2	22. Sept 2005	GzB	Section 2 (footnotes), section 4.2 (Icc, Vbat)

We reserve all rights in this document and in the information contained therein. Reproduction, use or disclosure to third parties without express authority is strictly forbidden.

For most recent documents, please visit [www.u-blox.com](http://www.u-blox.com)

<b>Data Sheet Revisions</b>	<b>Identification of applicable hardware</b>	<b>Comments</b>
P1, P2	All data codes	

The specifications in this document are subject to change at u-blox' discretion. u-blox assumes no responsibility for any claims or damages arising out of the use of this document, or from the use of modules based on this document, including but not limited to claims or damages based on infringement of patents, copyrights or other intellectual property rights. u-blox makes no warranties, either expressed or implied with respect to the information and specifications contained in this document. u-blox does not support any applications in connection with active weapon systems, ammunition, life support and commercial aircraft. Performance characteristics listed in this document are estimates only and do not constitute a warranty or guarantee of product performance.

The copying, distribution and utilization of this document as well as the communication of its contents to others without expressed authorization is prohibited. Offenders will be held liable for the payment of damages. All rights reserved, in particular the right to carry out patent, utility model and ornamental design registrations.

u-blox, the u-blox logo and ANTARIS are registered trademarks of u-blox AG. NavLox, u-center, FixNOW, SuperSense and EKF are trademarks of u-blox AG. Other trademarks are property of the respective companies. Copyright © 2005, u-blox AG

# Contents

<b>1</b>	<b>Functional Description</b>	<b>4</b>
1.1	Overview	4
1.2	Block Diagram	4
1.3	Features	4
1.4	Operating Modes	5
1.5	Protocols	5
1.6	Assisted GPS (A-GPS)	5
1.7	Antenna	6
<b>2</b>	<b>Performance Specification</b>	<b>7</b>
<b>3</b>	<b>Mechanical Specification</b>	<b>8</b>
3.1	Dimensions	8
3.2	Specification	8
3.3	Pin Assignment	9
<b>4</b>	<b>Electrical Specification</b>	<b>10</b>
4.1	Absolute Maximum Ratings	10
4.2	Operating Conditions	11
<b>5</b>	<b>Environmental Specification</b>	<b>12</b>
<b>6</b>	<b>Product Lineup</b>	<b>13</b>
6.1	Default Settings	13
6.2	Ordering Information	13

# 1 Functional Description

## 1.1 Overview

The LEA-4H module combines high sensitivity, exceptionally low power consumption and a USB port in a small module measuring just 17 x 22 mm. The -158 dBm tracking sensitivity extends positioning coverage into places where GPS was not possible before, and enables solutions using smaller or covert antennas.

Its small form factor and SMT pads allow for fully automatic assembly processes with standard pick-and-place equipment and reflow soldering, enabling cost-efficient, high-volume production. The combination of these features makes this module suitable for a broad spectrum of GPS products whose key requirements include high sensitivity, low power consumption and small size.

## 1.2 Block Diagram

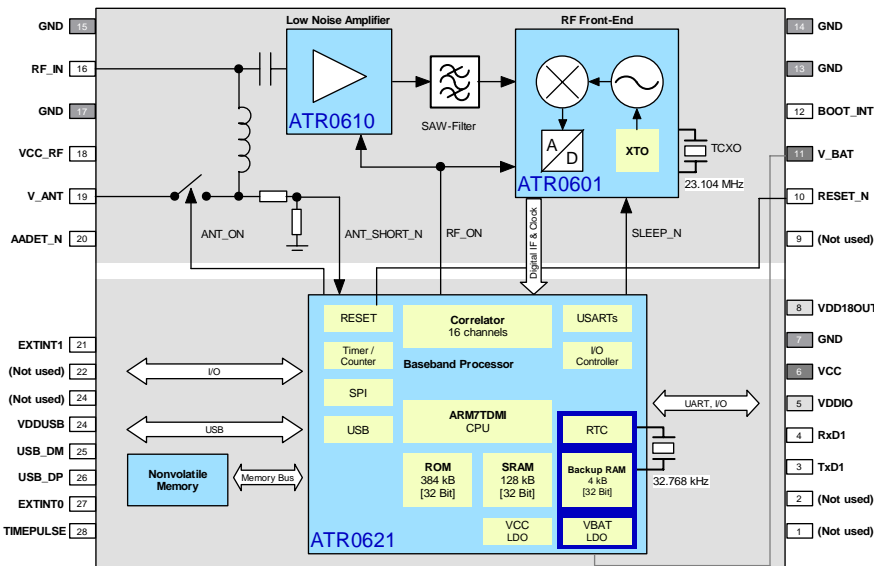

Figure 1: Block Diagram

## 1.3 Features

- 38 mA supply current (Power reduction by more than 35% compared to predecessor modules)
- USB connectivity
- Same functionality in 40% smaller footprint
- Significantly lower battery backup current
- Configurable I/O and UART voltage levels
- RoHS compliant (lead-free)
- SuperSense Indoor GPS
- 16 channel ANTARIS 4 positioning engine
- 1 Hz position update rate
- Assisted GPS (MS-Assisted, MS-Based)
- DGPS and full SBAS (WAAS, EGNOS) support
- FixNOW™ power saving mode
- Supports passive and active antennas
- Antenna short and open circuit detection and protection
- Operating temperature range: -40 to 85°C
- Optional Features:
  - Output of raw tracking data, max. 10 Hz
  - 2-channel precision time mark / counter

## 1.4 Operating Modes

The ANTARIS 4 GPS Technology supports following Operating Modes:

Operating Modes	Description
<b>Continuous Tracking Mode (CTM)</b>	The Continuous Tracking Mode is the default mode for normal GPS operation. In this mode, the Autonomous Power Management (APM) will automatically optimize power consumption transparently to the use where parts of the receiver are switched off when not required. Also, the CPU speed is reduced when the CPU workload is low.
<b>FixNOW™ Mode (FXN)</b>	FixNOW™ Mode is a configurable power saving mode where the GPS is put into sleep mode and activated up on a selectable time interval or upon external request (signal activity on serial port or EXTINT input). This mode is ideally suited in applications with stringent power budget requirements in mobile and battery operated end products.

**Table 1: Operating Modes**

For more information see the *System Integration Manual for ANTARIS 4* [1].

## 1.5 Protocols

The LEA-4H supports different serial protocols.

Protocol	Type	Runs on
NMEA	Input/output, ASCII, 0183, 2.3 (compatible to 3.0)	All Serial ports
UBX	Input/output, binary, u-blox proprietary	All Serial ports
RTCM	Input, message 1,2,3,9	All Serial ports

**Table 2: Available Protocols**

For specification of the various protocols see the *Protocol Specification* [2].

## 1.6 Assisted GPS (A-GPS)

The ANTARIS 4 GPS engine supports both MS assisted (output of raw tracking information for position computation by the service provider) and MS based (accelerated acquisition and position computation in the GPS receiver) A-GPS. Supply of aiding information like ephemeris, almanac, rough last position and time and satellite status and an optional time synchronization signal will reduce time to first fix significantly.

## 1.7 Antenna

This GPS receiver is designed for use with passive and active antennas. An antenna supervisor is provided. If activated, the GPS receiver is capable of detecting short circuits to the active antenna by checking the bias voltage level and can shut down the voltage bias immediately. A series resistor is needed in front of the **V\_ANT** input. UBX and NMEA messages are provided to report the condition of the antenna supply. Open circuit detection can also be supported with an additional external circuit. For details, please refer to the *System Integration Manual for ANTARIS 4* [1].

Parameter	Specification	
Antenna Type	Passive and active antenna	
Active Antenna Recommendations	Minimum gain	10 - 15 dB (to compensate signal loss in RF cable)
	Maximum noise figure	1.5 dB
	Maximum gain	50 dB
Antenna Supply	Using <b>VCC_RF</b> or external voltage source	
Antenna Supervisor	Short circuit detection	Built-in
	Open circuit detection	Enabled with external circuit

**Table 3: Antenna Specification**

- ! Note** When using active antennas, it is important to recognize the voltage drop of the bias voltage through the coaxial cable. A too low voltage has a negative impact on the gain the pre-amplifier in the antenna can achieve. In addition, the coaxial cable, connector and layout structures on the printed circuit board contribute to signal attenuation.

## 2 Performance Specification

Parameter	Specification			
Receiver Type	L1 frequency, C/A Code, 16-Channels 8192 time / frequency search windows			
Max Navigation Update Rate	1 Hz			
Accuracy	Position	2.5 m CEP <sup>2</sup>	5.0 m SEP <sup>3</sup>	
	Position DGPS / SBAS <sup>1</sup>	2.0 m CEP	3.0 m SEP	
Acquisition <sup>4, 5</sup>		Fast Acquisition Mode	Normal Mode	High Sensitivity Mode
	Cold Start	34 s	36 s	41 s
	Warm Start	33 s		
	Hot Start	<3.5 s		
	Aided Start <sup>6</sup>	5 s		
	Reacquisition	<1 s		
Sensitivity <sup>7</sup>	Tracking	-158 dBm		
	Acquisition & Reacquisition	-148 dBm	Includes aided starts (A-GPS)	
	Cold Starts	-142dBm		
Accuracy of Timepulse Signal and 2-channel Time Mark / Counter	RMS	50 ns		
	99%	<100 ns		
	Granularity	43 ns		
Dynamics	Strong signals	≤ 4 g		
	Weak signals	typ. 1 g		
Raw Tracking Data (Optional)	Contents	Carrier and Code Phase, Doppler measurements		
	Max. Update Rate	10 Hz		
Operational Limits (COCOM)	Altitude	18,000 mg		
	Velocity	515 m/s		
	One of the limits may be exceeded but not both.			

**Table 4: Performance Specification**

<sup>1</sup> Depends on accuracy of correction data of DGPS or SBAS service

<sup>2</sup> CEP = Circular Error Probability: The radius of a horizontal circle, centered at the antenna's true position, containing 50% of the fixes.

<sup>3</sup> SEP = Spherical Error Probability. The radius of the sphere, centered at the true position, contains 50% of the fixes.

<sup>4</sup> The different start-up modes like cold, warm and hot start are described in the System Integration Manual [1]

<sup>5</sup> Measured with good visibility and -125 dBm signal strength

<sup>6</sup> Time synch. signal from aiding source must be supplied to **EXTINT0** or **EXTINT1** pin, having accuracy of better than 200 µs

<sup>7</sup> Demonstrated with a good active antenna

## 3 Mechanical Specification

### 3.1 Dimensions

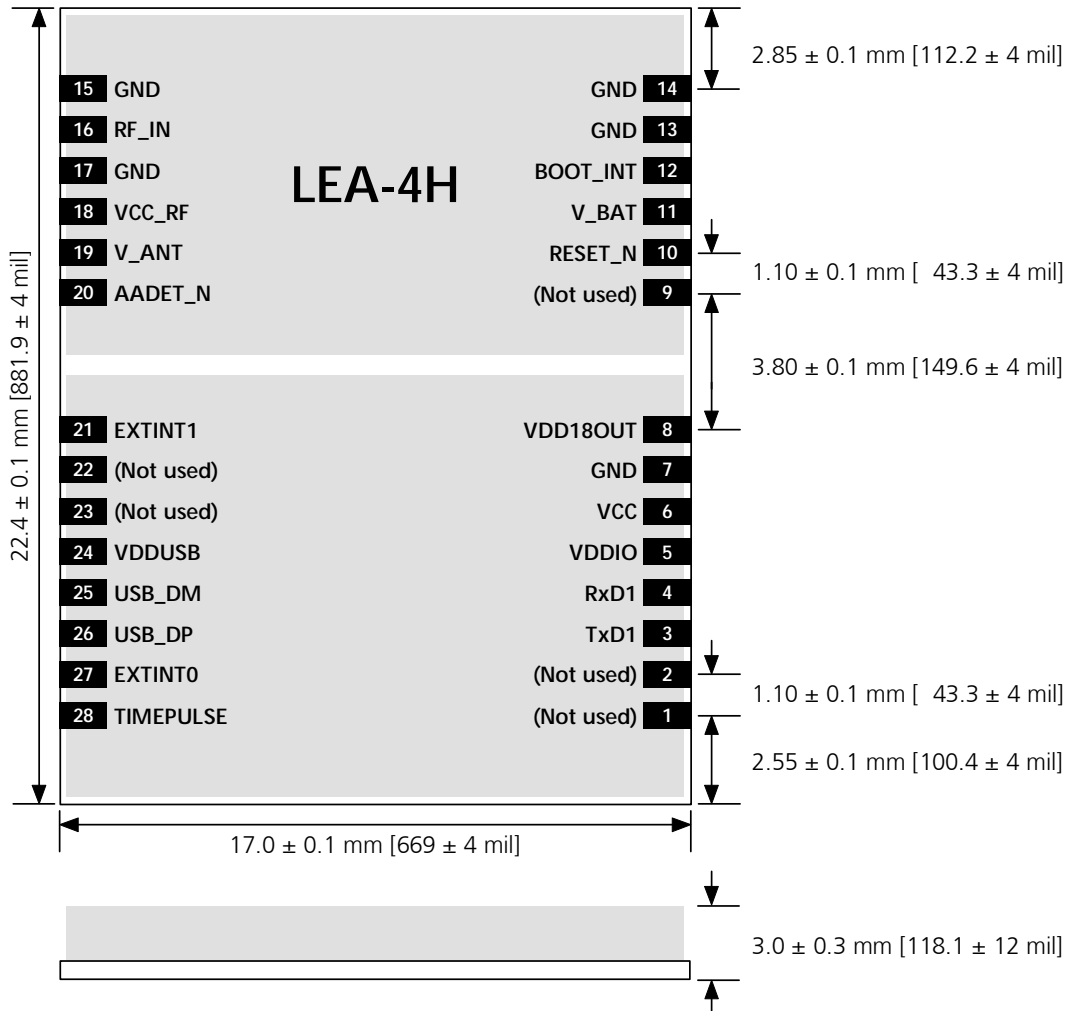

Figure 2: LEA-4H Dimensions

### 3.2 Specification

Parameter	Specification	Tolerance	Unit
Length	22.4	$\pm 0.1$	mm
Width	17.0	$\pm 0.1$	mm
Thickness	3.0	$\pm 0.3$	mm
Pitch RF pins	1.1	$\pm 0.1$	mm
Pitch Digital pins	1.1	$\pm 0.1$	mm
Weight	2.1		g

Table 5: Mechanical Specification



### 3.3 Pin Assignment

Standard Function				Remarks
No	Name	I/O	Description	
1	-	I	( Not assigned )	Default configuration: Input, internal pull-up
2	-	I	( Not assigned )	Default configuration: Input, internal pull-down
3	TxD1	O	Serial Port 1	
4	RxD1	I	Serial Port 1	Internal pull-up
5	VDDIO	I	Pad voltage supply	
6	VCC	I	Supply voltage	
7	GND	I	Ground	
8	VDD18OUT	O	1.8V output	
9	-	I	( Not assigned )	Default configuration: Input, internal pull-up
10	RESET_N	I/O	Reset	Open drain
11	V_BAT	I	Backup voltage supply	
12	BOOT_INT	I	Boot mode	Default configuration: Input, internal pull-down
13	GND	I	Ground	
14	GND	I	Ground	
15	GND	I	Ground	
16	RF_IN	I	GPS signal input	Apply no DC through this pin
17	GND	I	Ground	
18	VCC_RF	O	Output Voltage RF section	
19	V_ANT	I	Antenna Bias voltage	
20	AADET_N	I	Active Antenna Detect	Default configuration: Input, internal pull-down
21	EXTINT1	I	External Interrupt Pin	Internal pull-up
22	-	I	( Not assigned )	Default configuration: Input, internal pull-up
23	-		( Not assigned )	Default configuration: Input, internal pull-up
24	VDDUSB	I	USB Supply	
25	USB_DM	I/O	USB Data	
26	USB_DP	I/O	USB Data	
27	EXTINT0	I	External Interrupt Pin	Internal pull-up
28	TIMEPULSE	O	Time pulse (1PPS)	

Table 6: Signals and Module Interface

- ! Attention** The **TxD1** and **TIMEPULSE** pins are powered with the **VDDIO** pin.
- ! Attention** **RxD1**, **EXTINT0** and **EXTINT1** pins are powered with battery backup pins. Do not pull up (e.g. to VCC) or pull down to GND as current may flow and therefore current drawn from the backup battery may increase.

## 4 Electrical Specification

### 4.1 Absolute Maximum Ratings

Parameter	Symbol	Min	Max	Units
<b>Power Supply</b>				
Power supply voltage (VCC)	Vcc	-0.3	3.6	V
I/O supply voltage (VDDIO)	Vddio	-0.3	3.6	V
Backup battery voltage (V_BAT)	Vbat	-0.3	3.6	V
<b>Input Pins</b>				
Input pin voltage (all except RESET_N)	Vin	-0.3	5	V
Input pin voltage of RESET_N	Vin_reset	-0.3	1.95	V
Input pin voltage VDDUSB	Vin_usb	-0.3	3.6	V
Input pin voltage USB_DP, USB_DM	Vin_usbio	-1	4.6	V
<b>Voltage Supply output for Active Antenna and RF Section</b>				
VCC_RF output current	Iccrf		50	mA
<b>RF Input</b>				
Antenna bias voltage (applied via V_ANT)	Vant	0	6	V
Antenna bias current (applied via V_ANT)	Iant		100	mA
Input power at RF_IN (source impedance 50Ω, continuous wave)	Prfin		-5	dBm
<b>Environment</b>				
Storage temperature	Tstg	-40	85	°C

**Table 7: Absolute Maximum Ratings**

- ! Warning** Stressing the device beyond the “Absolute Maximum Ratings” may cause permanent damage. These are stress ratings only. The product is not protected against overvoltage or reversed voltages. If necessary, voltage spikes exceeding the power supply voltage specification, given in table above, must be limited to values within the specified boundaries by using appropriate protection diodes.

## 4.2 Operating Conditions

Parameter <sup>8</sup>	Symbol	Condition	Min	Typ	Max	Units
<b>Power Supply</b>						
Power supply voltage (VCC)	Vcc		2.7		3.3	V
I/O supply voltage (VDDIO)	Vddio		1.65		3.6	V
Power supply voltage ripple	Vcc_PP				50	mV
Sustained supply current <sup>9</sup>	Icc	Vcc = 3.0 V		38		mA
Peak supply current <sup>10</sup>	Iccp	Vcc = 3.3 V			TBD	mA
Sleep mode current	Iccs	Vcc = 3.0 V		80	TBD	µA
Backup battery voltage	Vbat		1.5		3.6	V
Backup battery current	Ibat	Vbat = 3.3V		5	TBD	µA
1.8V output voltage (VDD18_Out pin)	Vdd18out		1.65	1.8	1.95	V
1.8V output current (VDD18_Out pin)	Idd18out			30	TBD	mA
<b>UART and all I/O Signals<sup>11</sup></b>						
Input pin voltage range	Vin		0		5	V
Input pin low voltage	Vin_low				0.41	V
Input pin high voltage	Vin_high		1.46			V
Output pin voltage range	Vout		0		VDDIO	V
Output pin low voltage	Vout_low	Iout = 0.3 mA			0.1	V
Output pin high voltage	Vout_high	Iout = 0.3 mA	VDDIO-0.1			V
<b>USB</b>						
VDDUSB (Pin 24) for USB operation	Vddusb1		3.0		3.6	V
VDDUSB (Pin 24) if USB not used (low)	Vddusb0		0		2	V
USB_DM, USB_DP	VinU	Compatible with USB with 27 Ohms series resistance				
<b>RESET_N Input (Open-Drain I/O)</b>						
Input and output pin voltage range	VinR		0		1.8	V
Input pin low voltage	Vin_lowR				0.65	V
Input pin high voltage	Vin_highR		1.2			V
Output pin low voltage	Vout_lowR	Iout = 0.3 mA			0.1	V
Output pin high voltage	Vout_highR	Iout = 0.1 mA	VDD18-0.2			V
<b>RF input</b>						
Antenna gain	Gant				50	dB
V_ANT antenna bias voltage (must connect to ground if not used)	Vant		1.8		6	V
Antenna bias voltage drop	Vant_drop	Iant=10mA		20	50	mV
VCC_RF voltage	Vccrf			Vcc - 0.1		V
VCC_RF output current	Iccrf			20	50	mA
<b>Environment</b>						
Operating temperature	Topr		-40		85	°C

**Table 8: Operating Conditions**

Operation beyond the "Operating Conditions" is not recommended and extended exposure beyond the "Operating Conditions" may affect device reliability.

<sup>8</sup> All specification are at an ambient temperature of 25°C.

<sup>9</sup> Average current drawn during Continuous Tracking Mode with 1 Hz update rate, using 9 channels for tracking and navigation and 3 channels for searching satellites (= acquisition). Use this figure to determine required battery capacity.

<sup>10</sup> Peak current drawn during initial acquisition phase. Use this figure to dimension maximum current capability of power supply.

<sup>11</sup> RxD1, EXTINT0 and EXTINT1 provide internal pull-up to V\_BAT18 (Battery supply regulated to 1.8V) and not VCC.

## 5 Environmental Specification

Detailed description of the test series:

Test		Standard
Visual inspection		IPC-A-610 "Acceptability of electronic assemblies" I.T.R.I. Publication No. 700 IPC-SM-840B Class 2.
Thermal shock	-40°C...+125°C, 100 cycles	IEC 68-2-14
Function at various temperatures	-40°C/2 hours; RT/2 hours; +85°C/2 hours; function tests at stable temperature	IEC 68-2-1 and IEC 68-2-2
Lifespan test	+85°C/1000 hours, in function	IEC 68-2-2
Damp heat, cyclic	+25°C...+55°C; >90% rH	IEC 68-2-30
Vibration	10-500 Hz; 2 hours/axis; 5g	IEC 68-2-6
Shock	30g/11ms (half sine); 3 Shock/axis; no function	IEC 68-2-27
Metallographic investigations		IPC-QE-650

**Note:** This specification is preliminary and yet subject to confirmation.

**Table 9: Environmental Specification**

## 6 Product Lineup

### 6.1 Default Settings

Please refer to the *System Integration Manual for ANTARIS 4* [1] for information about further settings.

Interface	Settings
Serial Port 1 Output	9600 Baud, 8 bits, no parity bit, 1 stop bit Configured to transmit both NMEA and UBX protocols, but only following NMEA and no UBX messages have been activated at start-up: <b>GGA, GLL, GSA, GSV, RMC, VTG, ZDA, TXT</b> Additional messages can be activated with appropriate input messages or with GPSPINMODE pins.
Serial Port 1 Input	9600 Baud, 8 bits, no parity bit, 1 stop bit, Autobauding disabled Automatically accepts following protocols without need of explicit configuration: <b>UBX, NMEA, RTCM</b> The GPS receiver supports interleaved UBX and NMEA messages.
USB Output	9600 Baud, 8 bits, no parity bit, 1 stop bit, Autobauding disabled Automatically accepts following protocols without need of explicit configuration: <b>UBX, NMEA, RTCM</b> The GPS receiver supports interleaved UBX and NMEA messages.
USB Input	Same protocol and message set as via Serial Port 1
TIMEPULSE	1 pulse per second, synchronized at rising edge, pulse length 100ms

Table 10: Available Protocols

### 6.2 Ordering Information

Ordering No.	Product
LEA-4H-0-000-0	LEA-4H GPS Receiver Module <u>Delivery Packing</u> 0 = Single samples 1 = Tape on reel (100 pieces)
Optional Features	Please contact your u-blox sales office

Table 11: Ordering Information

Parts of this product are patent protected.

## Related Documents

- [1] System Integration Manual for ANTARIS 4, Docu. No GPS.G4-MS4-05007
- [2] ANTARIS 4 Protocol Specification, Docu. No GPS.G4-X-05003

All these documents are available on our homepage (<http://www.u-blox.com>).

## Contact

For further info, please contact us:

### Headquarters

#### u-blox AG

Zuercherstrasse 68  
CH-8800 Thalwil  
Switzerland

Phone: +41 44 722 74 44  
Fax: +41 44 722 74 47  
E-mail: [info@u-blox.com](mailto:info@u-blox.com)

[www.u-blox.com](http://www.u-blox.com)

### Sales Offices

#### North, Central and South America

##### u-blox America, Inc.

13800 Coppermine Road  
Herndon, VA 20171  
USA

Phone: +1 (703) 234 5290  
Fax: +1 (703) 234 5770  
E-mail: [info\\_us@u-blox.com](mailto:info_us@u-blox.com)

##### Regional Office West Coast:

8600 Lemon Ave #1  
La Mesa, CA 91941  
USA

Phone: +1 (619) 741 3011  
Fax: +1 (619) 741 4334  
E-mail: [info\\_us@u-blox.com](mailto:info_us@u-blox.com)

##### Technical Support:

Phone: +1 (703) 234 5290  
E-mail: [support\\_us@u-blox.com](mailto:support_us@u-blox.com)

#### Europe, Middle East, Africa

##### u-blox AG

Zuercherstrasse 68  
CH-8800 Thalwil  
Switzerland

Phone: +41 44 722 74 77  
Fax: +41 44 722 74 47  
E-mail: [info@u-blox.com](mailto:info@u-blox.com)

##### Technical Support:

Phone: +41 44 722 74 74  
E-mail: [support@u-blox.com](mailto:support@u-blox.com)

#### Asia, Australia, Pacific

##### u-blox Asia Pacific Ltd.

435 Orchard Road  
#19-03, Wisma Atria,  
Singapore 238877

Phone: +65 6734 3811  
Fax: +65 6732 9987  
E-mail: [info\\_ap@u-blox.com](mailto:info_ap@u-blox.com)

##### Technical Support:

Phone: +852 3111 1913  
E-mail: [support\\_ap@u-blox.com](mailto:support_ap@u-blox.com)